

4.0 installations plan



View looking south on west side of the Huron Church Road greenbelt to the north of the Green Bridge

4.1 introduction

The purpose of the Huron Church Road Installation Plan Summary is to provide additional detail on the streetscape installation identified in the Master Plan Design, propose an installation implementation plan, present feedback from the stakeholder consultation process and to demonstrate the refined project goals and design concepts. The Installation Plan Summary was prepared during Phase 3 of the Huron Church Road Urban Design process and builds on The Opportunities and Constraints Analysis and The Master Plan Design.

A Master Plan Vision was created based on the preliminary goals, community feedback and the Opportunities and Constraints Analysis from that process, a list of streetscape installations were developed. On December 1st, 2005 the refined Master Plan Design and the Installation Plan was presented to the Windsor community at an Open House. The feedback received is summarized in Section 7.0 and is reflected the Final Recommended Master Plan Design and the Development Guidelines.

The Installation Plan builds on the Section 2 recommendation that the appearance, design and function of Huron Church Road should be characterised by a positive and coherent image that expresses the unique identity of Canada, Ontario, Essex and Windsor.

4.2 installation plan, at-a-glance

This comprehensive illustration is individually detailed in larger formats on the following pages

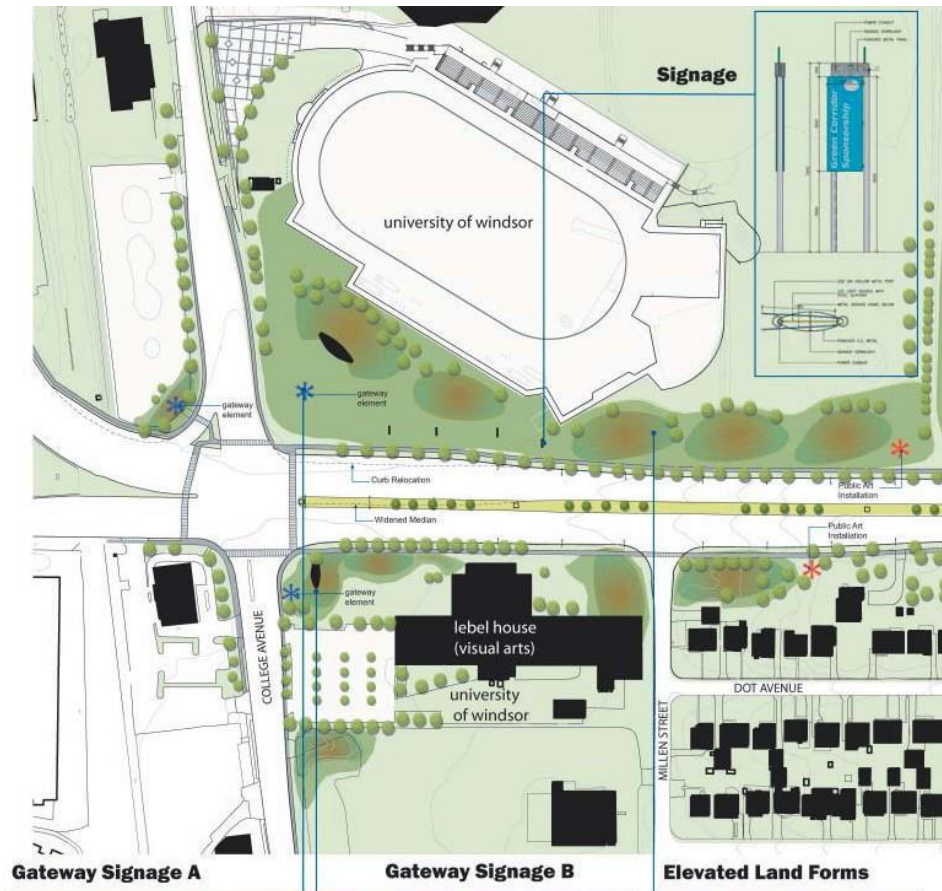

Gateway Signage A

The potential principal content of signage for the south east corner will relate to the University of Windsor Stadium name (to be determined), four pylon signs for sponsorship acknowledgement and a possible LED screen integrated into a vessel installation.

The primary intent of the LED displays will be to convey to the visitor a sense of the beauty and high quality of the Canadian and regional landscape and cultural offerings.

Subject to Sign Bylaw Amendment and/or agreements with University on matters of content, frequency of message changes, and light intensity.



Gateway Signage A - Elevation



Gateway Signage A - Plan

Gateway Signage B

The potential principal content of signage on the south-west corner will be a 'welcome' sign to Canada/Ontario/Windsor/Essex. A second smaller LED installation may also be considered for the south west lands.

New streetlight standards are proposed for HCR to be placed primarily on the boulevards, but with a median location for the first 60 metres at HCR and College. The design of light standards integrates tall banners that both complement the Green Corridor and provide opportunities for a signage program



Gateway Signage B - Elevation



Gateway Signage B - Plan

Elevated Land Forms

New landform patterns or 'earthworks' provide a new artificial landscape on either side of Huron Church Road that integrate with buildings, street lighting, surface materials and patterns to create a 'total environment' designed to represent all of the principle design themes including Canada, Creation of Environmental Awareness and Innovation. The new visual landscape will provide a one of a kind gateway experience in Windsor and Canada.

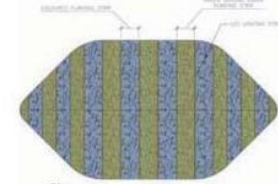

Plan



End Elevation

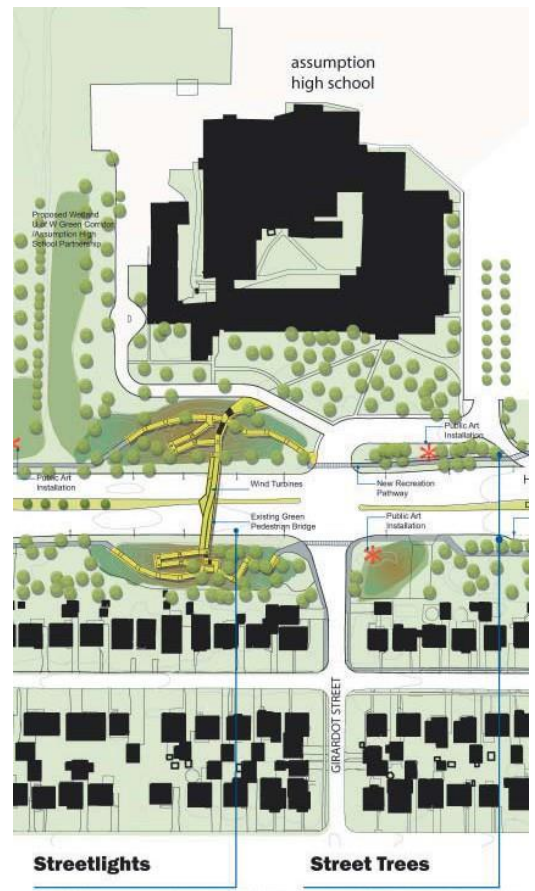

Streetlights

The design of light standards integrates tall banners that both complement the Green Corridor and provide opportunities for a signage program. The streetlights are constructed of powder-coated steel channels with leaf pattern filigree inserted in the gap between the two channel posts. LED lighting behind the filigree and on a top cylindrical mast provides accent lighting as part of the Green Corridor. It is proposed that an alternating pattern of light standards be used which places photovoltaic panels on every other standard in the same area as the banner.



Elevation of Median Streetlight

Plan of Median Streetlight

Street Trees

A canopy of diverse drought resistant and climate appropriate trees is integral to the redesign of Huron Church Road and is fundamental in establishing a friendlier pedestrian streetscape. Trees provide positive modification to our climate, help to diminish water and air pollution, mitigate sound and provide a desirable pedestrian environment.



Elevation of Boulevard Streetlight

Plan of Boulevard Streetlight

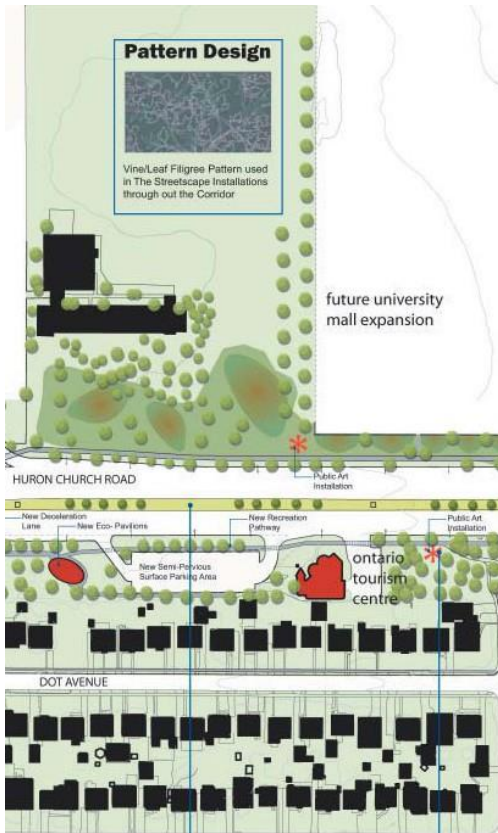

Median Design

A consistent median design is proposed utilizing a 1.0 metre concrete retaining wall embossed with a decorative concrete stamp reflecting the leaf/vine motif. Clusters columnar trees (English Oaks or Maples) alternate with both open areas planted with green ground cover and grasses and the 5 Median Totems.

Public Art

Locations for Integrated Public Art have been identified in the streetscape. Creating display venues in the open space areas of HCR provides an opportunity for the City to highlight the work of the Windsor Art Gallery and provide a role for the University of Windsor's Fine Arts Department in defining the Green Corridor concept.

Potential locations for permanent integrated public art (blue stars) and non-permanent (red stars) have been located.

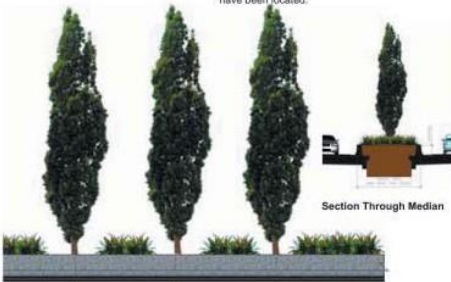

Elevation of Median



Median Totems

Interspersed with the columnar tree clusters are vertical installations incorporating punched metal screens (rear fit) with posts featuring content highlighting 5 eras of regional cultural settlement. The 5 eras preliminarily proposed area as follows:

- 10,000 years – Native American Se
- 1701 – French Settlement
- 1760 – British Settlement
- 1854 – Village of Windsor
- 1867 – Canadian Confederation

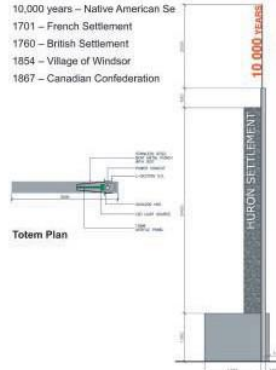

Elevation of Totem From North

10m Landscape Buffer

The landscape treatment proposed for the 10m Landscape Buffer adjacent to Huron Church Road employs smaller berms to ensure a uniform and unique design for the entire streetscape from Tecumseh to College.

A staggered tree pattern maintains the tree canopy of the street while allowing for diagonal views into the adjacent retail centre. The berms are framed into a low retaining wall that shields the parking areas from the street.

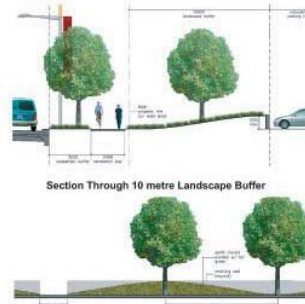

Elevation of 10 metre Landscape Buffer

Recreation Pathway

A new pathway system is proposed for the entire length of Huron Church Road, connecting into the pedestrian bridge on both the East and West sides of the road.

On the eastern side of the road, in the area of the raised landforms the pathway is inset into the sides of these berms in a location away from the street edge. To ensure that the area is friendly to both cyclists and pedestrians a 2.4m (min) multi use pathway is proposed for both sides of HCR. The crosswalk areas are to be defined by a striped pattern in a different material than the roadway.



Plan of Typical Intersection



4.3 installation designs

Elevated Landforms

New landform patterns or 'earthworks' provide a new innovative landscape on either side of Huron Church Road that integrate with buildings, street lighting, surface materials and patterns to create a 'total environment' designed to represent all of the principal design themes including Canada, Creation of Environmental Awareness and Innovation. The new visual landscape will provide a one of a kind gateway experience in Windsor and Canada.

On the University of Windsor lands and some portions of other land holdings raised berms (3:1 slope) up to a maximum height of 5m are proposed as an undulating landscape clearly visible to all travelling through the corridor. This landscape will be complemented by smaller rolling landforms that can be inserted into other areas where existing tree stands are located or where only the 10m landscape buffer can be utilized. The berms are designed to lessen the visual width of the road and the negative impact of the truck and car traffic.

Climate and site appropriate indigenous plantings will line the berms in alternating 4m wide bands. The rows will highlight the curve of the mound with strong geometric lines. This artificial landscape references the spirit of innovation found in Windsor and provides a visually dominant green landscape to reinforce the concept of the Green Corridor.

Planting materials should be chosen for its ability to withstand the climate of Windsor, for its visual interest throughout the year, and for ease of maintenance. A colourful range of planting that symbolizes the native species to Canada and it have a seasonal presence on the roadway are proposed. This is to be a designed landscape – not meant to replicate a natural setting – but intended to convey a new vision of nature integrated with the human-made world. Innovative maintenance techniques should be determined for optimal long-term appearance such as short and long-term landscape growth maturity.

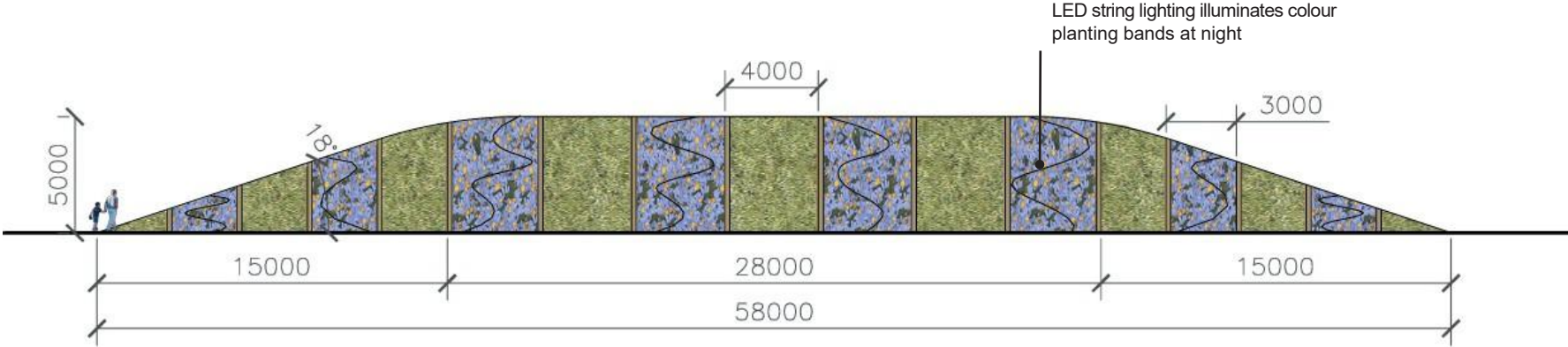

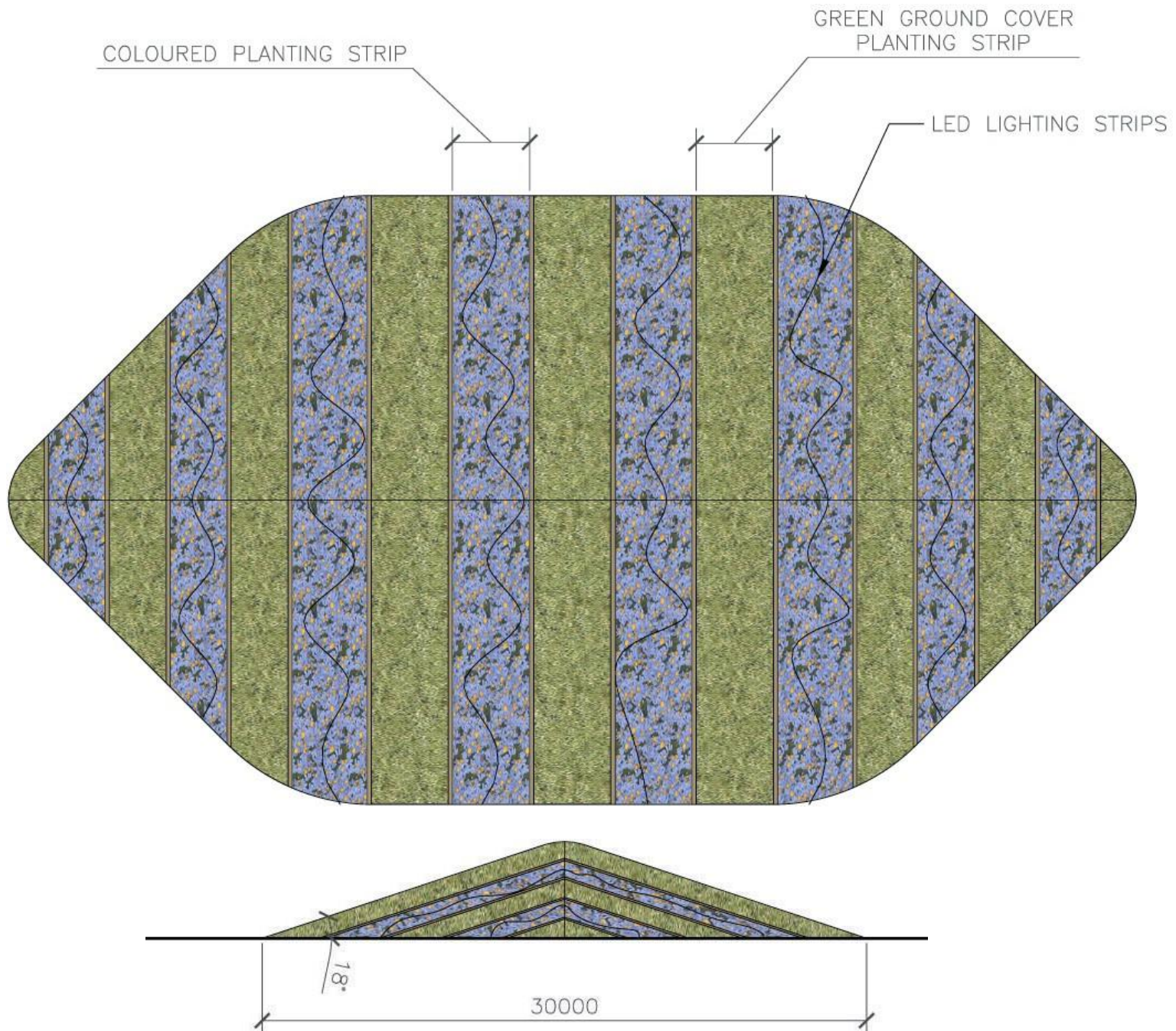

The Gateway

The principal gateway at Huron Church Rd. and College Ave. will consist of elevated landforms on either side planted with a colourful range of indigenous and archetypal Canadian plant materials. Two punched metal signage 'vessels' are located at either southern corner. The vessels act as potential signage locations and as a base for a potential LED screen.

Gateway Signage

The lands on three of the four corners at Huron Church Rd. and College Ave. are owned by the University of Windsor. The creation of an attractive and comprehensive gateway treatment will require a partnership between the University, the City and other potential funding entities (government or corporate). The University has indicated its interest in participating in the transformation of portions of its land holdings to develop both a Huron Church Gateway as well as the University's own 'Green Corridor' concept. These initiatives:

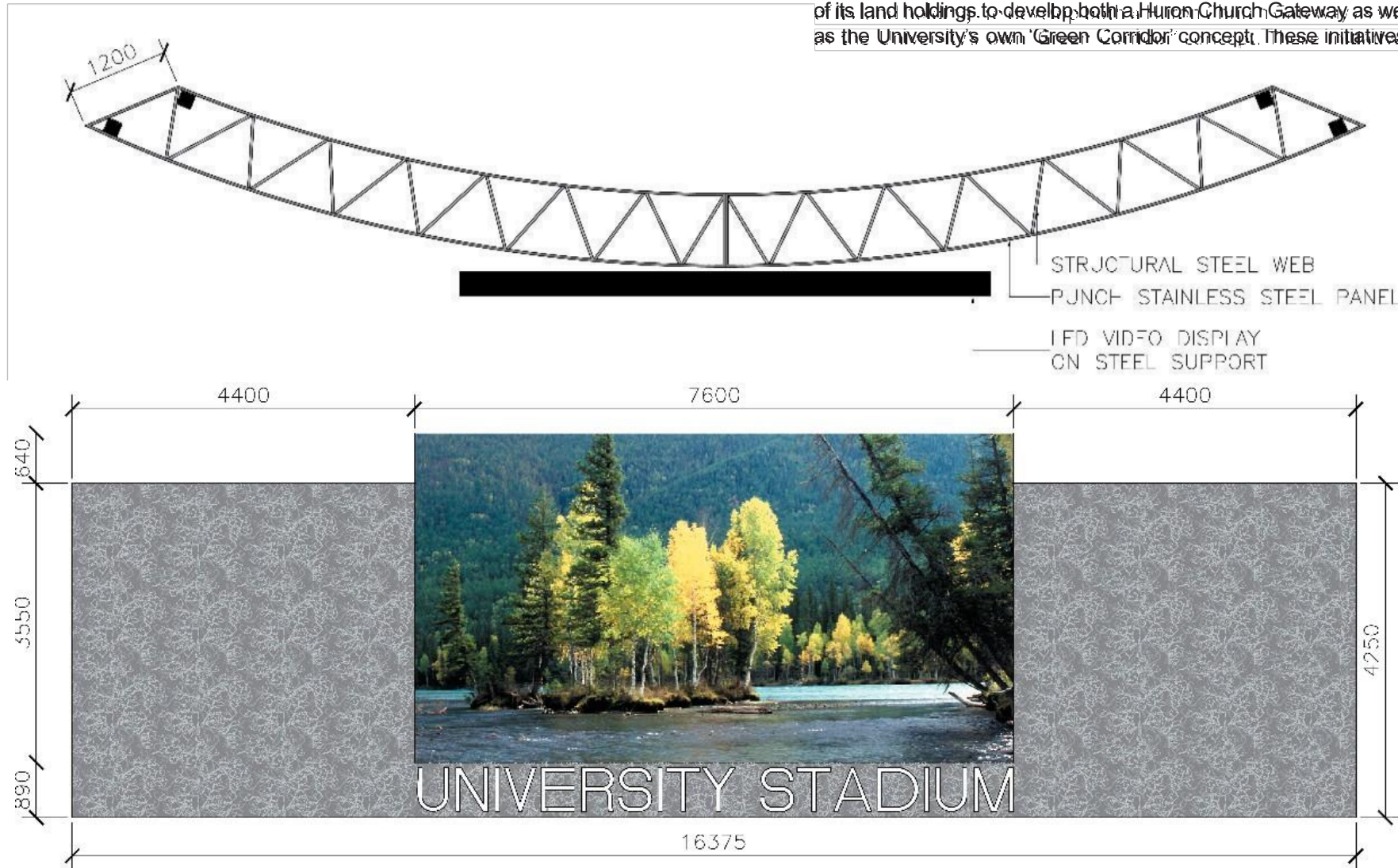

will require sponsorship funding from both the government and corporate donors. In return the University will need provision in the design for permanent signage that acknowledges these sponsorships. To accommodate this a new 'gateway district' is proposed as a special district within the signage by-law that encompasses the university's lands in the Huron Church Road vicinity between College Ave. and Tecumseh Road. The principal content of signage on the south-west corner will be a 'welcome' sign to Canada/Ontario/Windsor/Essex. The principle content of signage for the south east corner will relate to the University of Windsor Stadium name (to be determined), four pylon signs for sponsorship acknowledgement and a possible LED screen integrated into a signage installation. A second smaller LED installation may also be considered for the south west lands.

The primary intent of the LED displays will be to convey to the visitor a sense of the beauty and high quality of the Canadian and regional

landscape and cultural offerings. LED content shall be restricted to 'non-commercial' messages and will focus on artistically rendered video images and messages related to the following subject areas: Canada, Ontario, Essex, Windsor and University of Windsor tourism and cultural events and resources, welcome messages and public art showcase. Signage content is not intended for commercial advertising but will allow for sponsorship acknowledgment utilizing a corporate, institutional or government name and logo with a context message such as 'sponsor' or 'sponsor of ...'. A minor portion of content can be assigned to sponsorship recognition. This may take the form of time allocation...for instance 10% of an hour of LED programming can be assigned to sponsorship recognition.

Signage is subject to Sign Bylaw Amendment and/or agreements with University on matters of content, frequency of message changes, and light intensity.

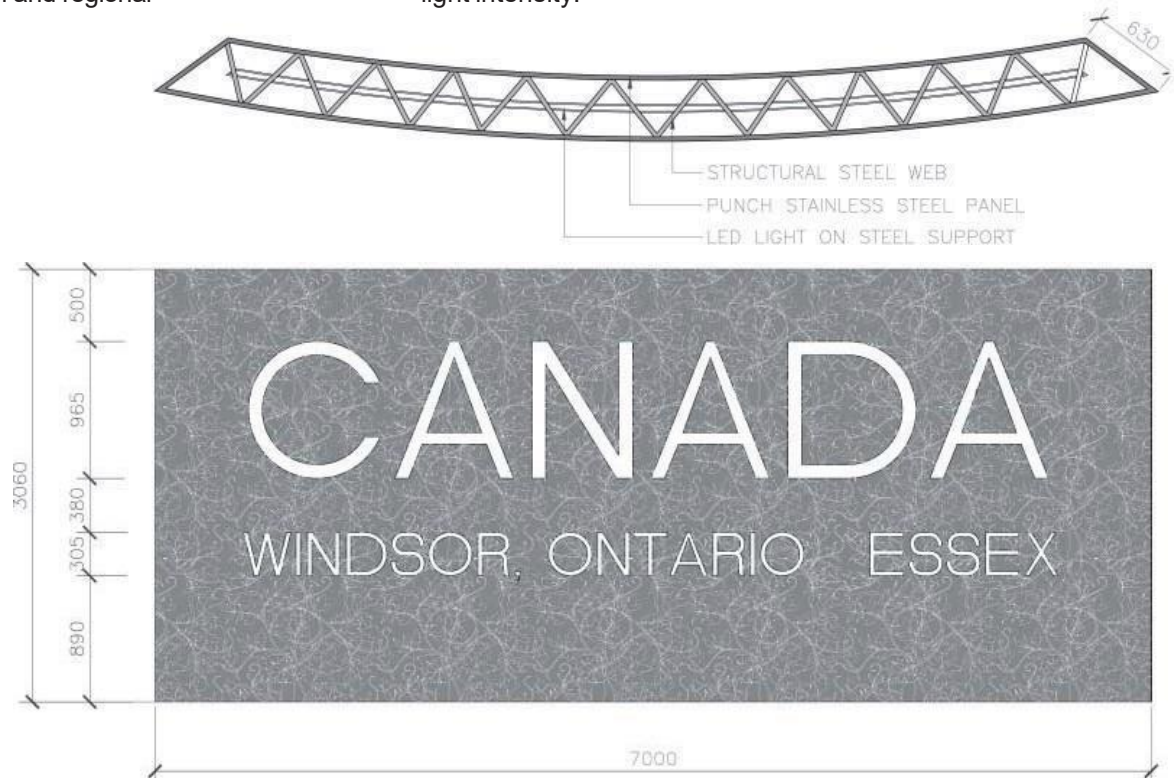

Street Lighting

New streetlight standards are proposed for Huron Church Road to be placed primarily on the boulevards, but with a median location for the first 60m at Huron Church Road and College Avenue. The design of light standards integrates tall banners that both complement the Green Corridor and provide opportunities for a signage program. The streetlights are constructed of steel channels with leaf pattern filigree inserted in the gap between the two channel posts. LED lighting behind the filigree and on a top cylindrical mast provides accent lighting as part of the Green Corridor. It is proposed that an alternating pattern of light standards be used which places photovoltaic panels on every other standard in the same area as the banner. Solar generated electricity may assist in powering LED and feed directly into the power grid.

Pedestrian and Decorative Lighting

In the design of the pedestrian lighting systems, special considerations were made to minimize the impacts of new lighting on adjacent residential properties while ensuring a safe and secure pedestrian environment. To achieve this different types of pedestrian lighting are employed through out the streetscape.

Pedestrian scaled lighting for the recreation pathway system is a light wash which cast a gentle light perpendicular to the face of the pathway. The wash provides lighting for pedestrians and cyclists but aims to minimize light pollution. The next lighting style is a discrete upright that illuminates a selection of existing and proposed trees that boarder the sidewalks or pathways. This light not only provides pedestrian lighting but highlights the green qualities of the corridor. Provision should be made for outdoor electrical outlets to support Christmas lighting. The pedestrian lighting serves two functions in the streetscape design by ensuring an appropriately lit pedestrian zone and by providing a visually interesting evening streetscape for vehicular travellers.

Accent landscape lighting is proposed to illuminate trees and colour planting bands on the raised landforms through the use of LED ribbon lighting embedded into the coloured planting bands.

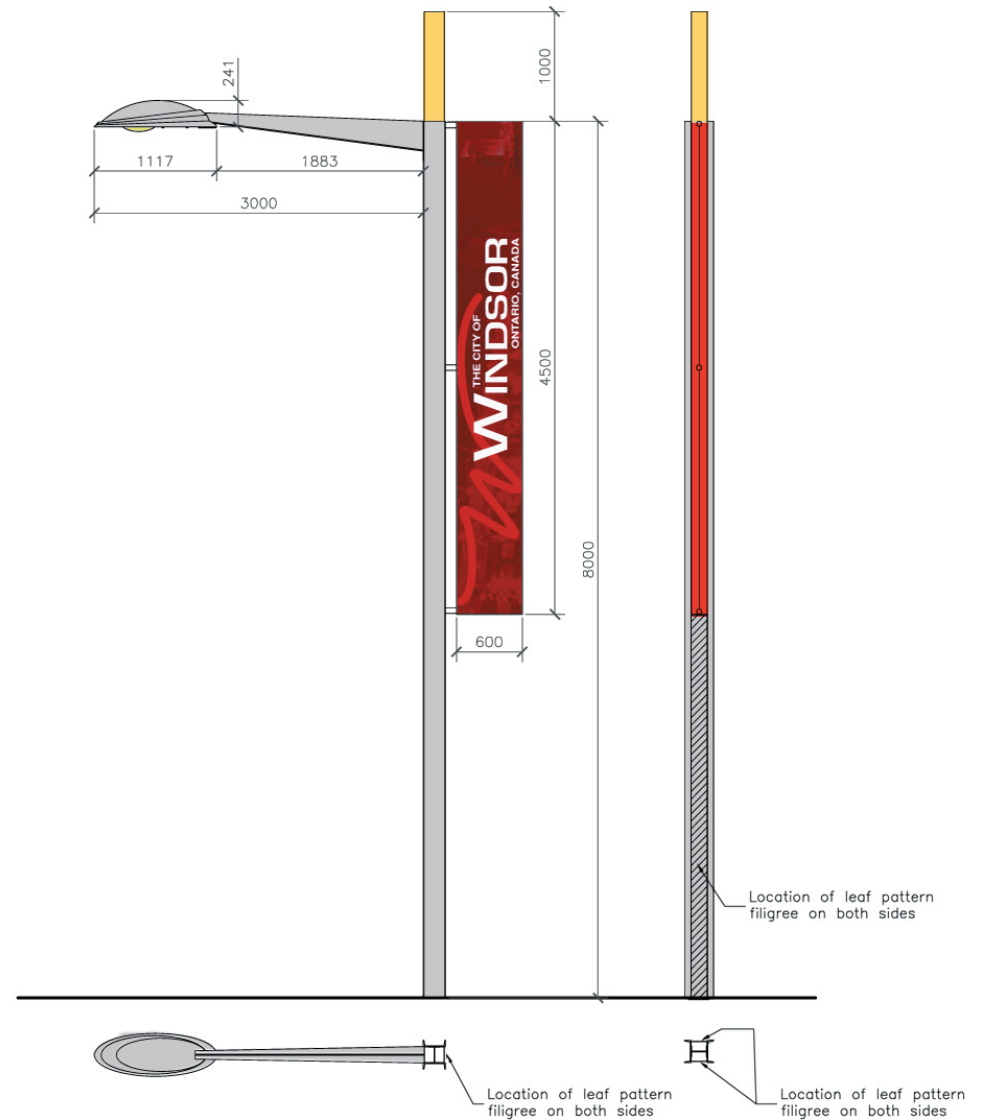

Standard street light standards proposed for Huron Church Road, primary and secondary study areas

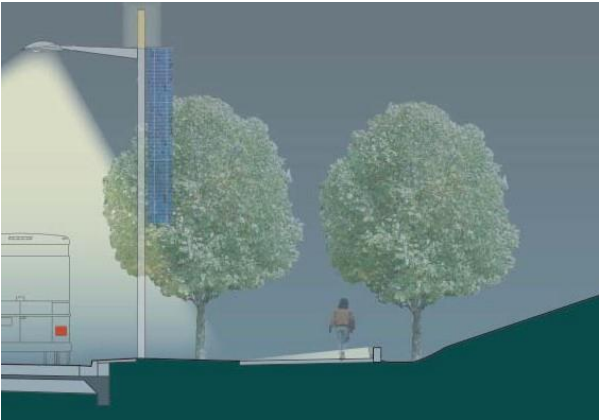

Pedestrian Lighting - Night view of pathway light wash



Decorative Lighting - Night view of tree uplights



Centre median light standards to be used approaching the intersection of College and Huron Church



Material Palette for Streetscape Elements

A punched metal element depicting a leaf/vine pattern has been designed specifically for Huron Church Road to reflect 'Industry and Innovation' in materiality and 'The Natural Environment' in pattern and content (as a planter). This design is to be used through out the new streetscape installations, in the gateway signage elements at Huron Church and College, in the median 'totems' and in the design of the pedestrian and street light standards. Not only does the pattern give the area a unifying design element, it will also provides a visible identity that will be exclusively associated with Huron Church Road. A local artist should be retained to develop a pattern that is representative of distinct local flora.

Recreation Pathway

A new 2.4m minimum wide multi-use recreation pathway is proposed for the entire length of Huron Church Road, on both the East and West sides of the road connecting into the pedestrian bridge. On the eastern side of the road, in the area of the raised landforms the pathway is adjacent to these landforms in a location away from the street edge. The pathway can in places be buffered from the road by a 3m zone incorporating a 0.6m splash strip and 2.4m turf strip that can accommodate street trees planted at 8m on centre.

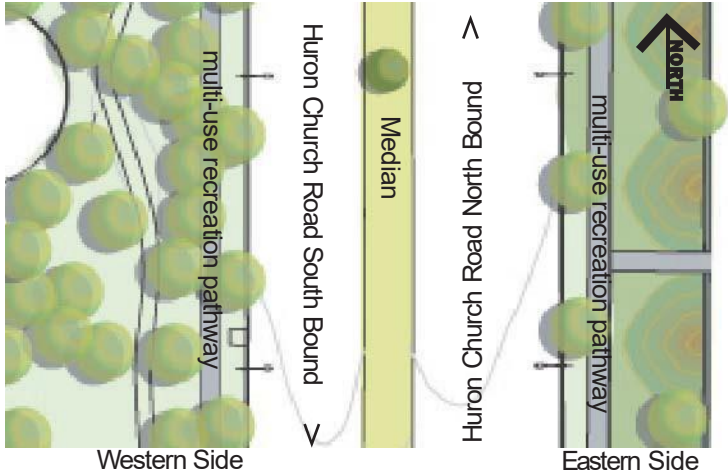
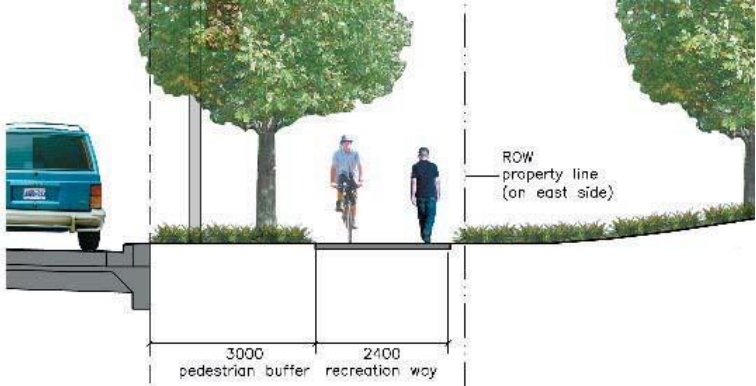
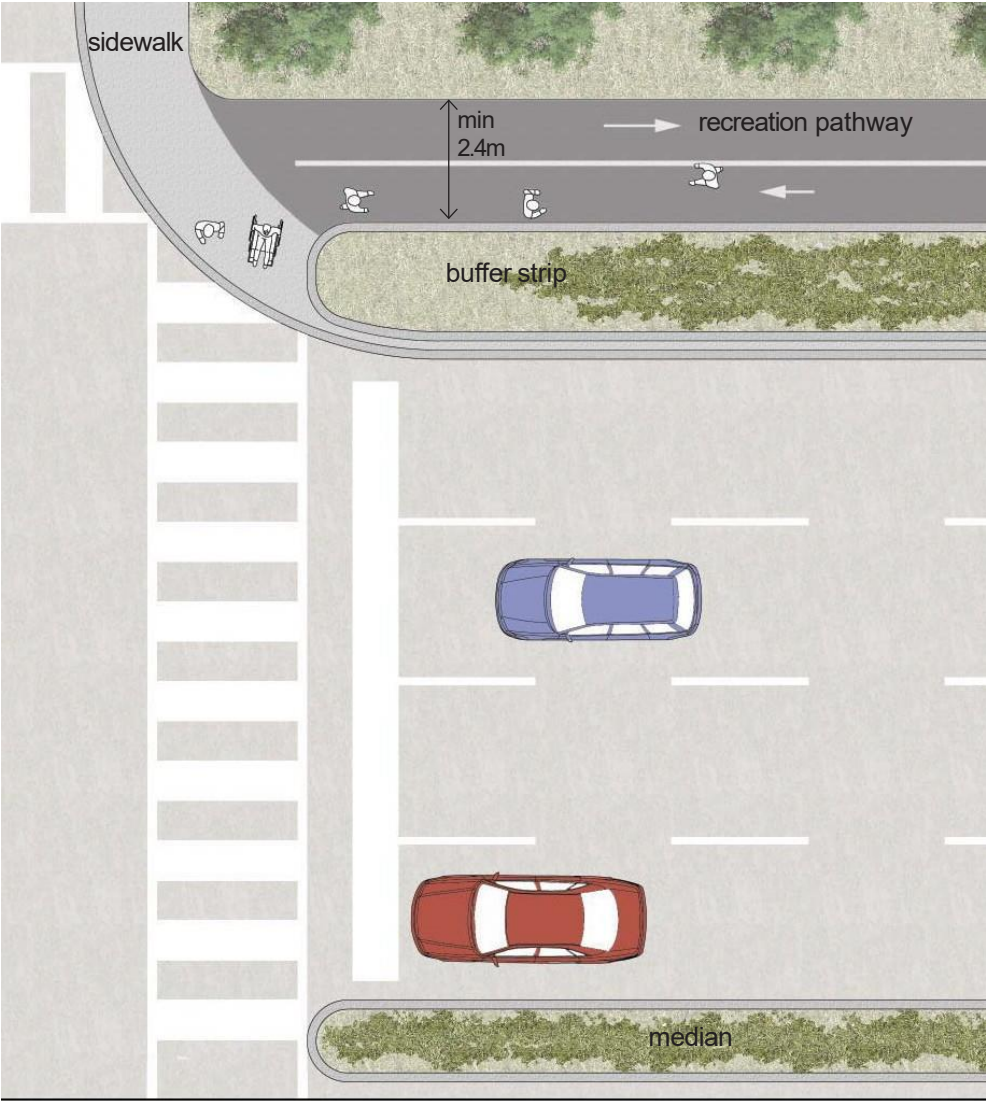

Public Art

Locations for Public Art have been identified in the streetscape. Creating display venues in the open space areas of Huron Church Rd. provides an opportunity for the City to highlight the work of the Art Gallery of Windsor and provide a role for the University of Windsor's Fine Arts Department in defining the Green Corridor concept.

Public competitions should be held to select pieces for these permanent displays. These works should ideally respond to the Streetscape Vision Principles of bringing awareness to environmental sustainability, Canadian identity, local industry, technology and innovation, tourism and education. Where public art locations occur on municipal property, these recommendations would be part of the purview of the recently created Windsor public art Advisory Committee.

Additional display locations have been identified for non-permanent displays of art. Preliminary locations have been identified due to their visibility from the street but the siting of individual pieces should reflect the nature of the work to be displayed. All pieces should incorporate a blending of art, landscape, Sustainability and innovation through integrated design. It is anticipated that sites for temporary display will evolve over time, creating a changing artscape within the City's Gateway.

These two pages show examples of public art from elsewhere to demonstrate the type of high quality design excellence that is required for Huron Church Road

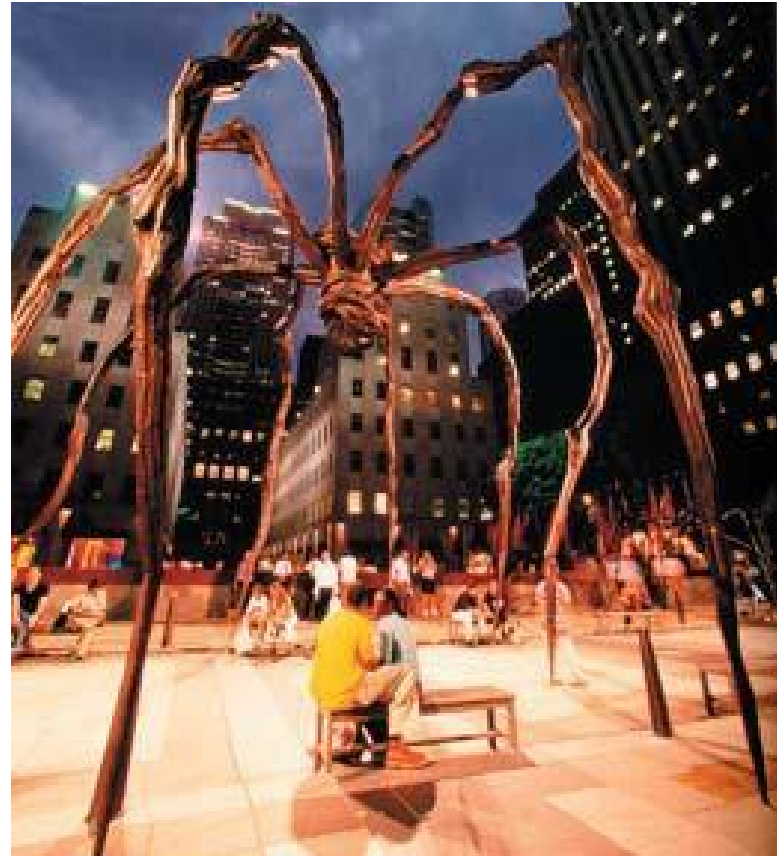

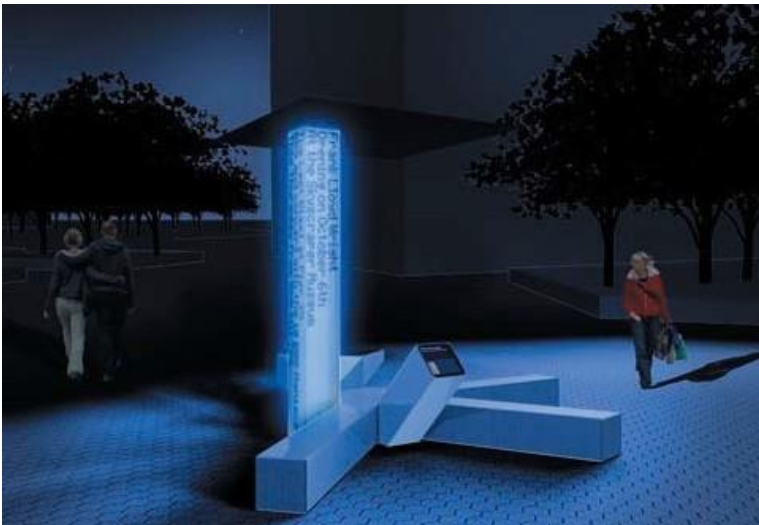

Medians

A consistent median design is proposed utilizing a 1m concrete retaining wall embossed with a decorative concrete stamp reflecting the leaf/vine motif. The new median is proposed in same location and is the same width as the existing median found on Huron Church Road, unless otherwise noted on the plan. Clusters of columnar trees such as English Oaks or Columnar Maples alternate with open areas planted with green ground cover and grasses and the 5 median Totems. Adequate sight lines for safe vehicular traffic movement must be maintained at all breaks in the median.



*note- Width of proposed median to match existing unless otherwise noted.



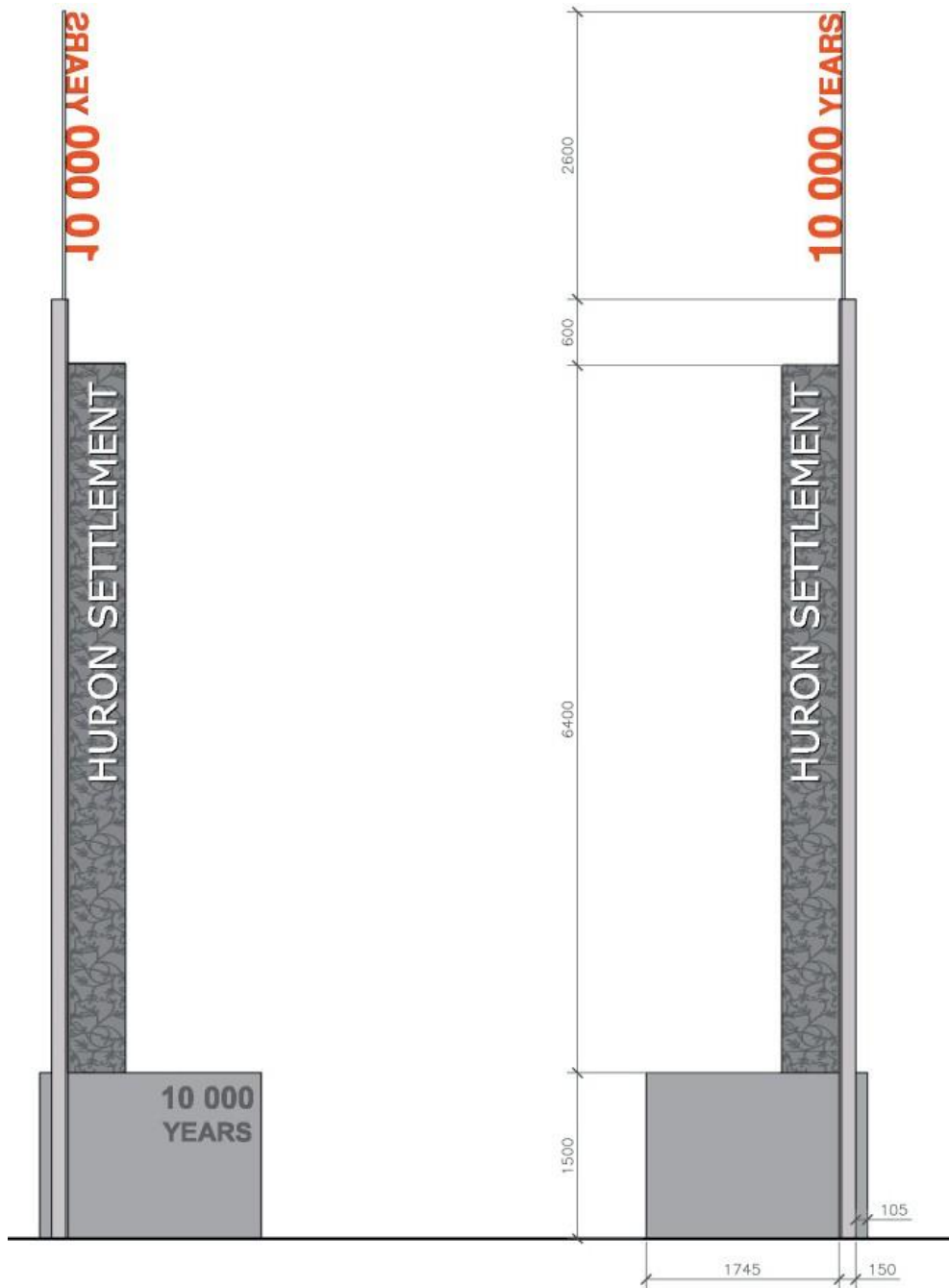

Totems

Interspersed with the columnar tree clusters are vertical installations incorporating punched metal screens (rear lit) with posts featuring content highlighting 5 eras of regional cultural settlement. The 5 eras preliminarily proposed area as follows:

- 10,000 years – Native American Settlement
- 1701 – French Settlement
- 1760 – British Settlement
- 1854 – Village of Windsor
- 1867 – Canadian Confederation

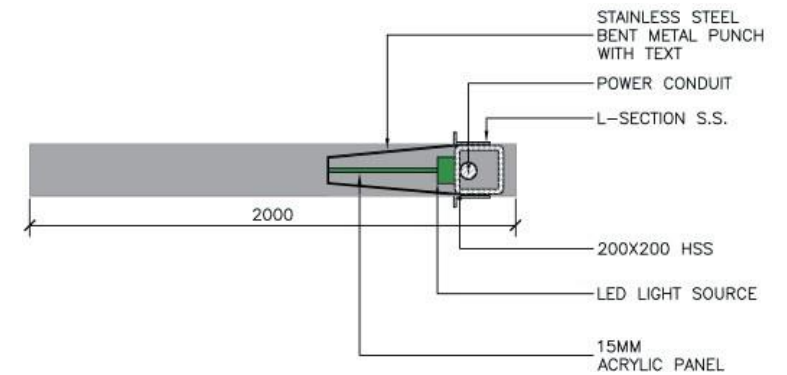



Figure 5.7

Park Trees

Acer ginnala Amur Maple

The Amur Maple species are small trees chosen for their compact, regular form, their intense red fall colour, and their ability to tolerate salt and adverse growing conditions. In the spring, the trees flower with clusters of fragrant, yellowish-white flowers.



Street Trees

Quercus rubra Red Oak

Red Oaks are sturdy street trees tolerant of urban pollution. Leaves first emerge as reddish in colour, become dark green in the summer and turn varying shades of red in the fall.



Trees

A canopy of diverse, drought resistant, climate appropriate trees is integral to the redesign of Huron Church Road and is fundamental in establishing a friendlier pedestrian streetscape. Trees provide positive modification to our climate, help to diminish water and air pollution, mitigate sound and provide a desirable pedestrian environment.

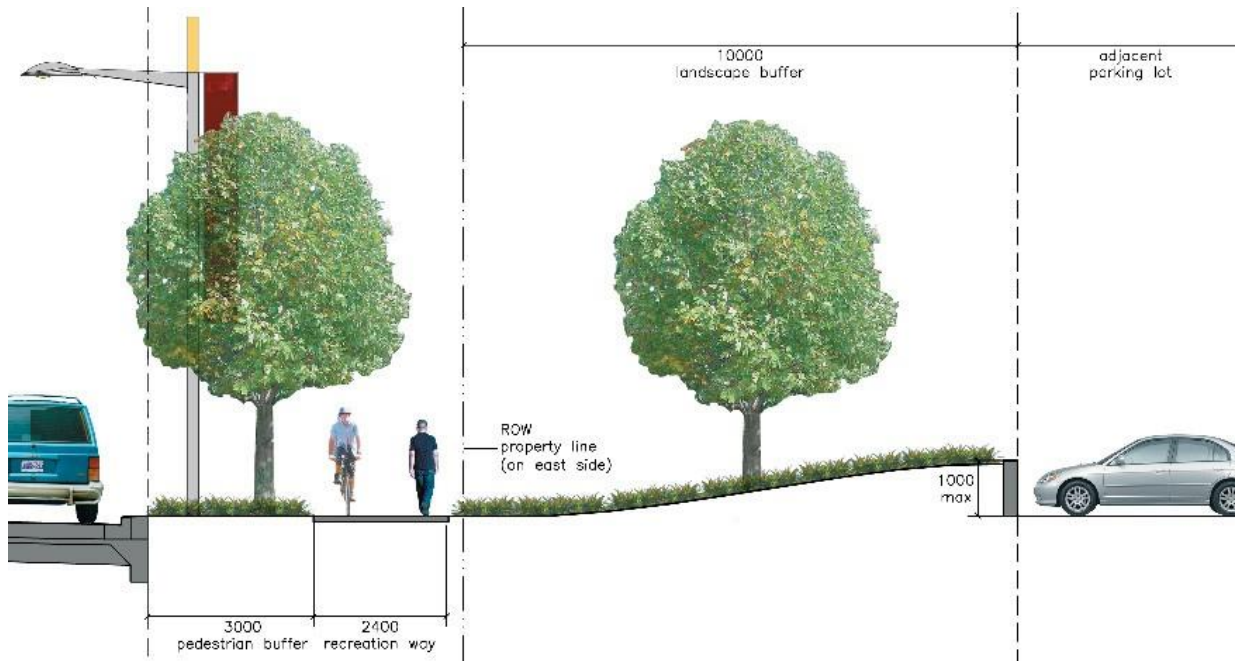

10m Landscape Buffer

The landscape treatment proposed for the 10m Landscape Buffer adjacent to commercial properties on Huron Church Road employs smaller berms to ensure a uniform and unique design for both the Primary and Secondary Study Areas.

A staggered tree pattern maintains the tree canopy of the street while allowing for diagonal views into the adjacent retail centre. The berms are framed into a low retaining wall that shields parking areas from the street.

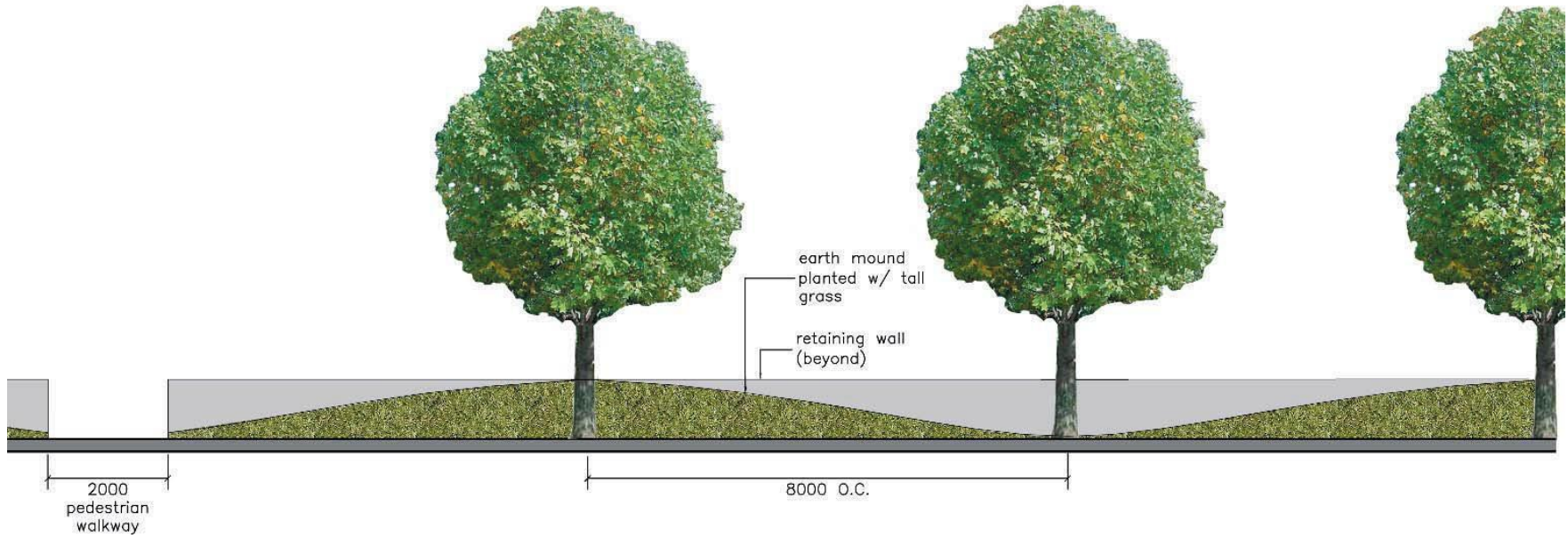

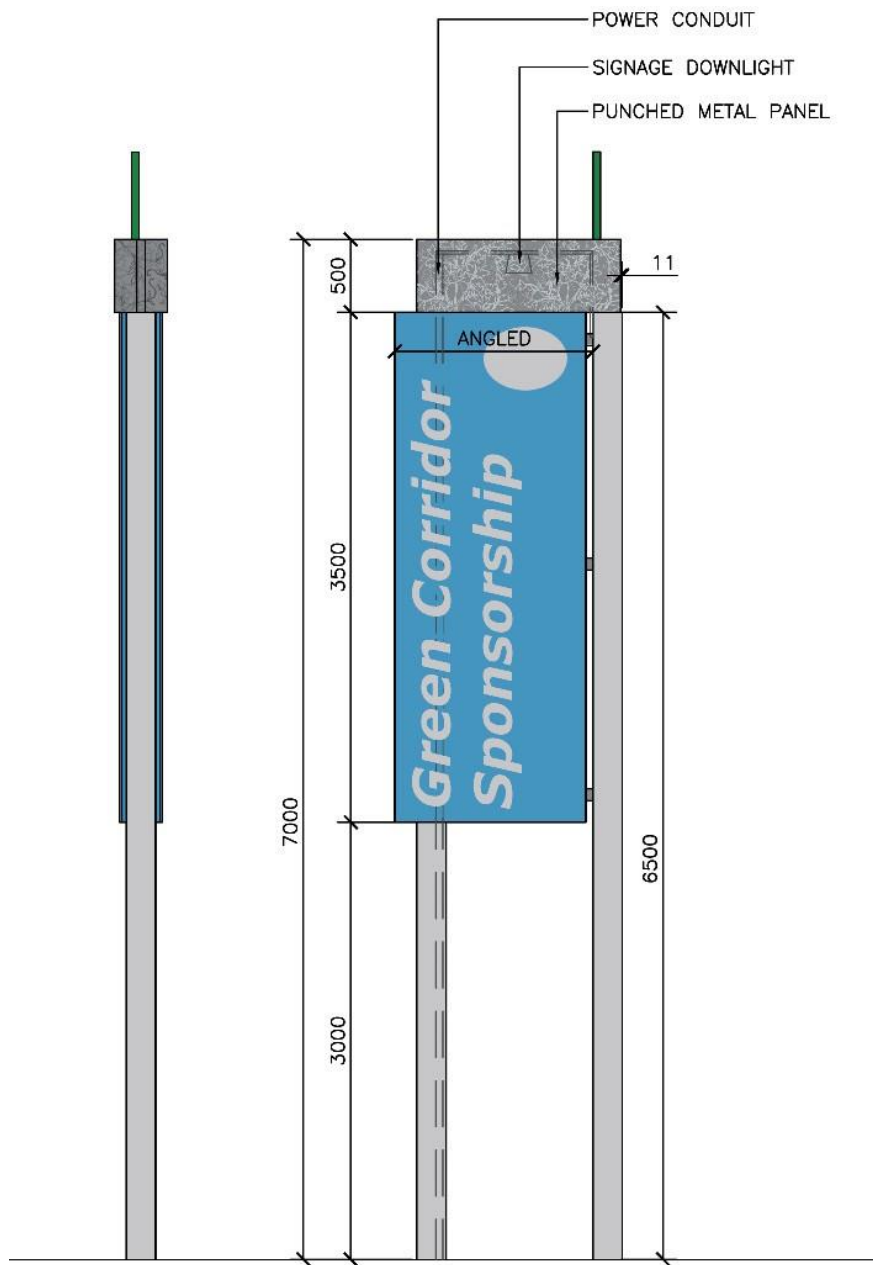

Signage

An integrated signage design has been developed using the common material palette from streetscape elements. The angled signage boards are supported on two cylindrical powered coated posts. The boards are illuminated from above with down lights that are enclosed by a punch metal cover that is back lit with LED accent lighting. The style and design of the individual boards can vary but should conform to the signage recommendation outlines in the Master Plan Summary and the Development Guidelines.

