

1. **SUBJECT:** BACKFILL OF DITCH/SWALE/TRENCH FRONTING A RESIDENTIAL OR COMMERCIAL PROPERTY.

*** BP 3.3.3 DOES NOT APPLY TO MUNICIPAL DRAINS**

2. **DEFINITION:**

Backfill: The act of filling an excavated trench, ditch, or swale.

3. **DRAWING:** AS-209A

4. **BEST PRACTICE:**

1. Location inspection required prior to permit
2. A permit is required for any work in the Municipal Right-of-Way (B/L 25-2010)
3. Pipe Material – PVC (Polyvinyl Chloride) or HDPE (High Density Polyethylene) or Concrete Pipe.
4. Match the existing upstream and downstream culvert size, whichever is greater. Minimum 15” (375mm) pipe.
5. Pipe to be embedded a minimum of 2” (50mm), or 10% of pipe diameter, whichever is greater.
6. Minimum pipe cover to be 1’-0” (300mm) of granular ‘A’ around pipe
7. Minimum 24” (600mm) diameter inline catchbasin with frame and cover is required at centreline of lot with additional catchbasins required every 40 ft (12.2m) ditch/swale.
8. Match upstream/downstream flow of ditch.
9. Maintain integrity of ditch at all times.
10. Not to be used as parking area unless approved by City Engineer. Blvd to be restored with grass.
11. Culvert to not extend beyond property line.
12. Jute bag headwalls with concrete cap for pipe diameter less than 18” (450mm), and pre-cast or engineered designed concrete headwalls approved by the City Engineer for pipe diameter greater than 18” (450mm) in accordance with AS-209.
13. All material used for backfill including native material shall be of a quality acceptable to the City Engineer and shall be in a thawed state when placing and compacting and be free from rocks, large or frozen lumps, wood, or other unsuitable material. No backfill material will be permitted to be placed on frozen substrate.

RELATED BEST PRACTICES;

BP2.2.1 – Driveway requirement policies-residential
BP2.1.1 – Commercial driveway approaches
BP2.3.1 – Driveway approaches
Spec 2 – Manholes, Catchbasins, and Adjustments
Spec 11 – Culverts Headwalls and Roadside Drainage

5. **RELATED CITY SPECIFICATIONS:**

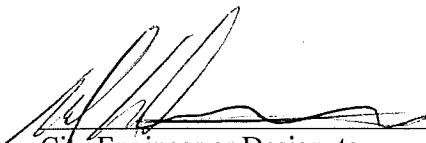

City Engineer or Designate
Attachment

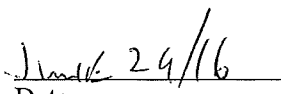

Date

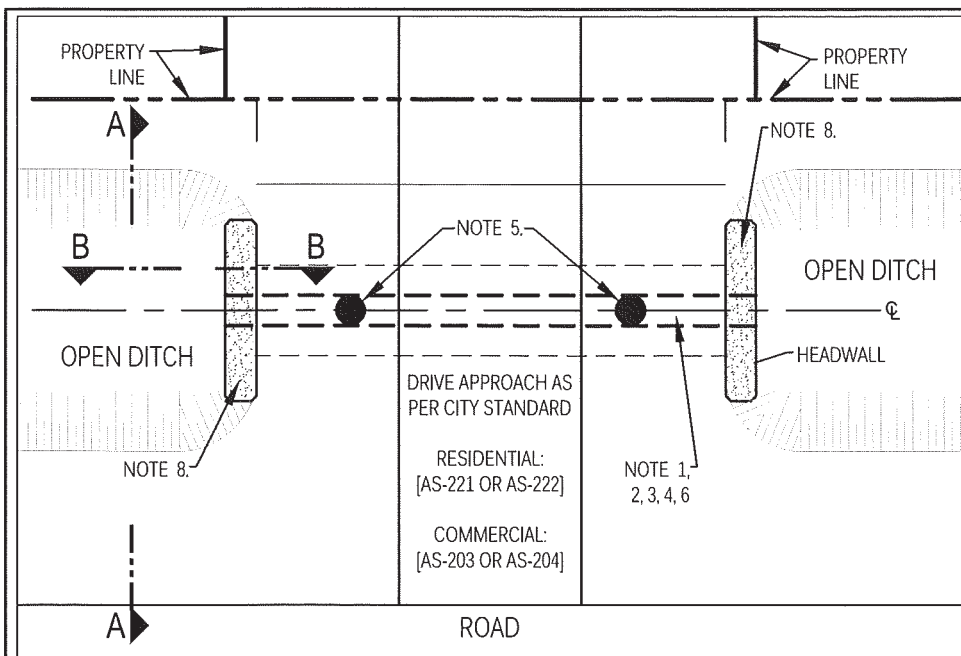

PLAN

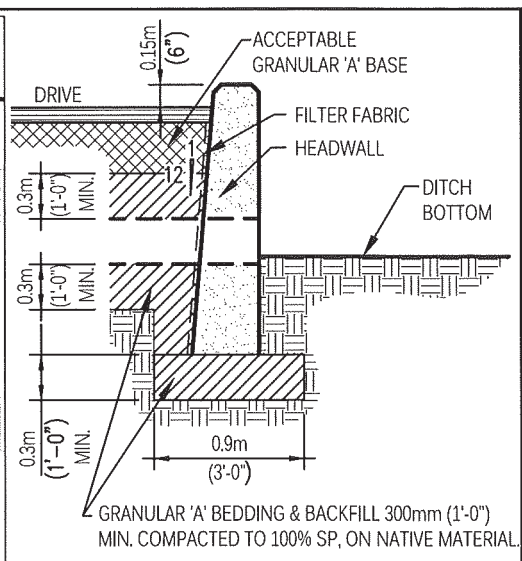

SECTION B-B

GENERAL NOTES:
(IN ACCORDANCE WITH CITY OF WINDSOR STANDARD SPECIFICATION S-11)

- 1.) PIPE MATERIAL - PVC (POLYVINYL CHLORIDE) OR HDPE (HIGH DENSITY POLYETHYLENE) OR CONCRETE PIPE.
- 2.) MATCH THE EXISTING UPSTREAM AND DOWNSTREAM CULVERT SIZE, WHICHEVER IS GREATER. MINIMUM 375mm (15") PIPE.
- 3.) PIPE TO BE EMBEDDED A MINIMUM OF 50mm (2"), OR 10% OF PIPE DIAMETER, WHICHEVER IS GREATER.
- 4.) MINIMUM PIPE COVER TO BE 300mm (1'-0") OF GRANULAR 'A' AROUND PIPE.
- 5.) MINIMUM 600mm (24") DIAMETER CONCRETE OR HDPE INLINE CATCHBASIN WITH FRAME AND COVER AS PER AS-301 IS REQUIRED AT CENTRELINE OF LOT WITH ADDITIONAL CATCHBASINS REQUIRED EVERY 12.2m (40') DITCH/SWALE. ROADWAY WITH CURB AND GUTTER AND/OR DEFINED SHOULDER STANDARD COVER PERMITTED.
- 6.) MATCH UPSTREAM/DOWNSTREAM FLOW OF DITCH.
- 7.) CULVERT TO NOT EXTEND BEYOND PROPERTY LINE.
- 8.) JUTE BAG HEADWALLS WITH CONCRETE CAP FOR PIPE DIAMETER LESS THAN 450mm (18"), AND PRE-CAST OR ENGINEERED DESIGNED CONCRETE HEADWALLS APPROVED BY THE CITY ENGINEER FOR PIPE DIAMETER GREATER THAN 450mm (18") IN ACCORDANCE WITH AS-209.

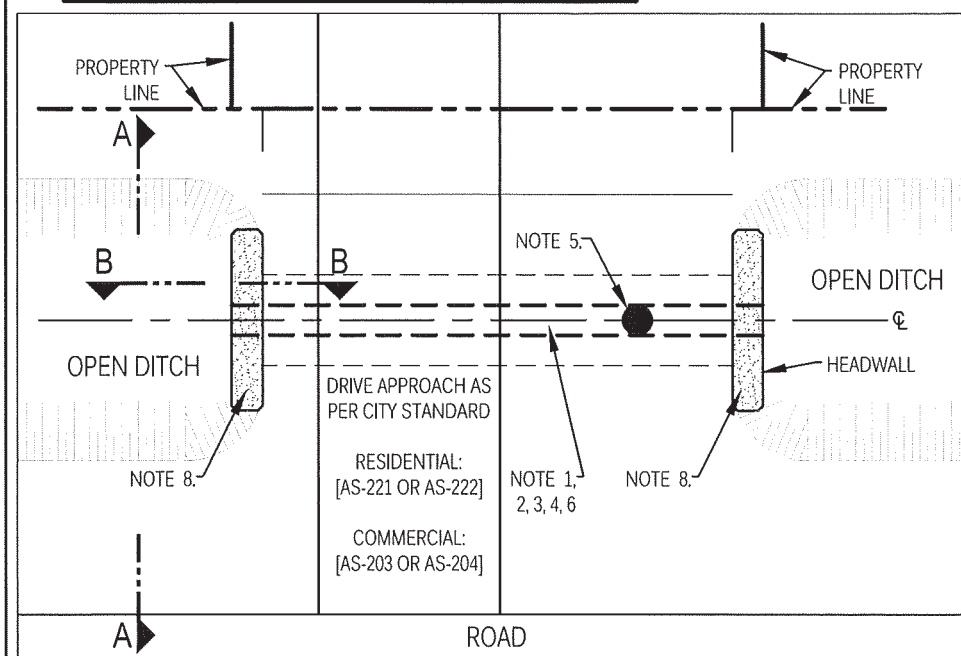

PLAN

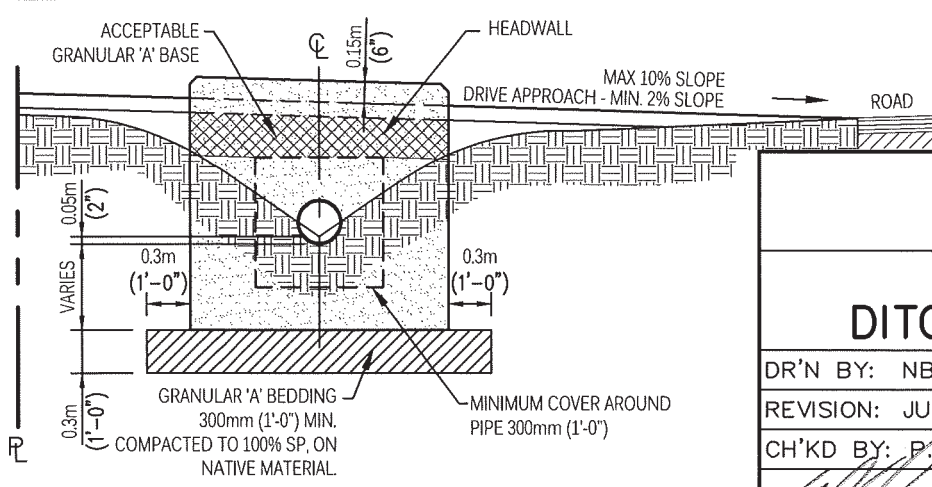

SECTION A-A

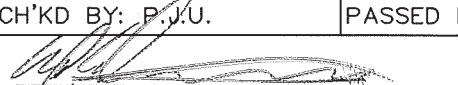
CITY OF WINDSOR	
ENGINEERING DEPARTMENT	
BACKFILL OF DITCH/SWALE/TRENCH	
DR'N BY: NB	DATE: SEPTEMBER, 2015
REVISION: JUNE 2018	CH'KD BY: A.B.
CH'KD BY: P.J.U.	PASSED BY:
 CITY ENGINEER	AS-209A