

CATCH BASIN BOX-OUT

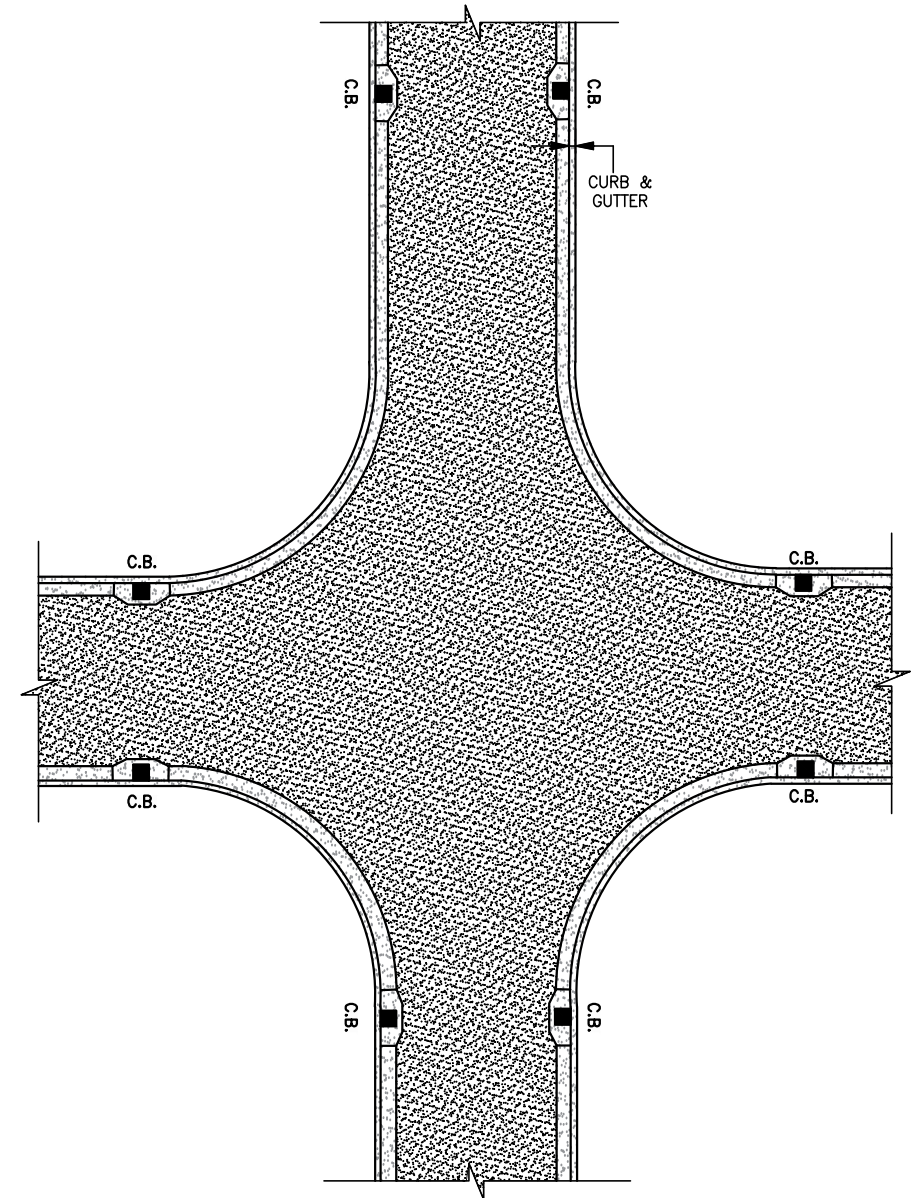

PLAN

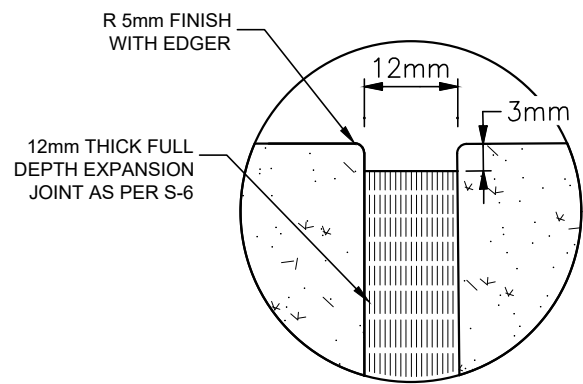

EXPANSION JOINT

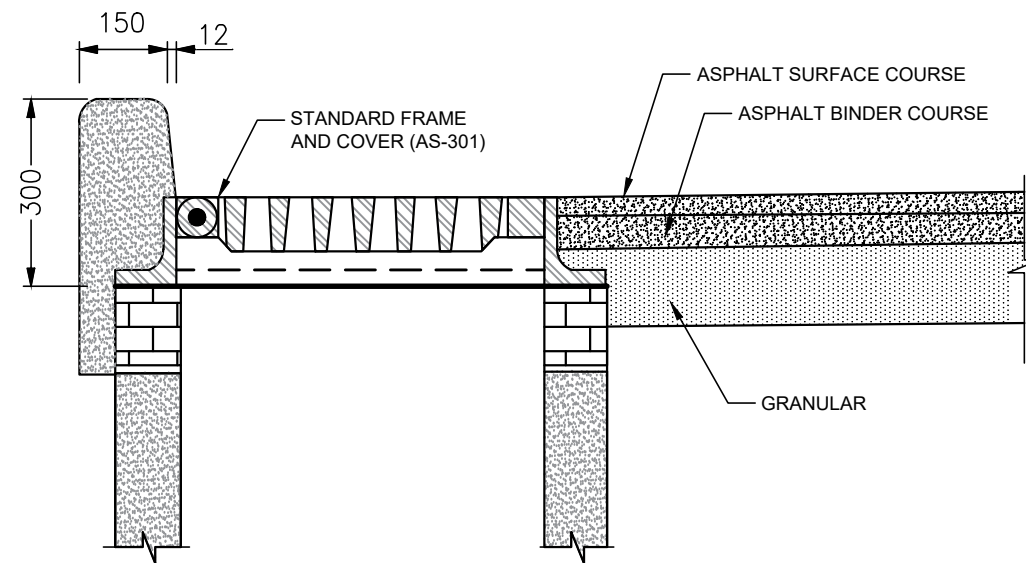

SECTION A-A

NOTES:

1. ALL DIMENSIONS ARE NOMINAL.
2. ALL DIMENSIONS ARE IN MILLIMETERS UNLESS OTHERWISE SHOWN.

NOT TO SCALE

| | |
|--|------------------------|
| CITY OF WINDSOR ENGINEERING DEPARTMENT | |
| CATCH BASIN BOX-OUT FOR ASPHALT PAVEMENT | |
| DR'N BY: ES, AZ | DATE: AUG, 1978 |
| REV. DATE: MAR, 2024 | CH'KD BY (ENG): PM, JH |
| CH'KD BY (GEO/OPS): PJU, AL | PASSED BY: FM |
| _____ CITY ENGINEER | AS-321 |